

ALKALINE WATER IONIZER

The Premier Water Ionization and Purification System



7 plates platinum with costly materials

- Product output rise by equipping 7-pole electrolyzer with platinum plating thickness (0.3 μ m)
- Maximization of ORP and hydrogen rich water producing (1500ppb)
- SMPS Power Supply with high-efficiency and low-power for preventing overload(450V/A) by **100% private own mold injection of Electrolyzer** (not ready-made mould)
- Equipped with ATF cleaning system and **brass water outlet nozzle**
- Smart Cleaning** according to the flow rate and time of use
- Solving standing-water problem by minimizing flow passages
- Two Block Carbon filter with best water purifying power
- CE Rohs /FCC / GMP certified



Durability enhancement

- **Anti Scale System** & Smart water saving system
- By minimizing flow passages and applying check valve of filter part, standing water issue can be solved
- Blocking foreign substances by **minimizing the use of tubes at flow passage** with private own injection moulding.
- **Minimizing consumable cost** by durability enhancement through product material change
- Solving scale problem by **automatic cleaning improvement** through product output rise (450 V/A)

User Convenience

- Luxurious display part by applying **LED display and touch buttons**
- Maximizing brand image by using water outlet nozzle part as brand logo
- When selecting purified water, water comes out **without draining** and without wasted water
- One-touch voice system display



Made in Korea

DRINKING WATER SYSTEM FOR HOME USE



TECHNOLOGY

Mimetic diagram of electrolysis within 3-tank electrolyzer

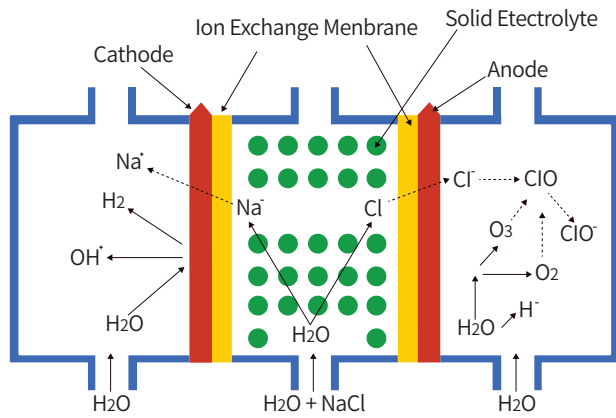

Electrolyzing Flow

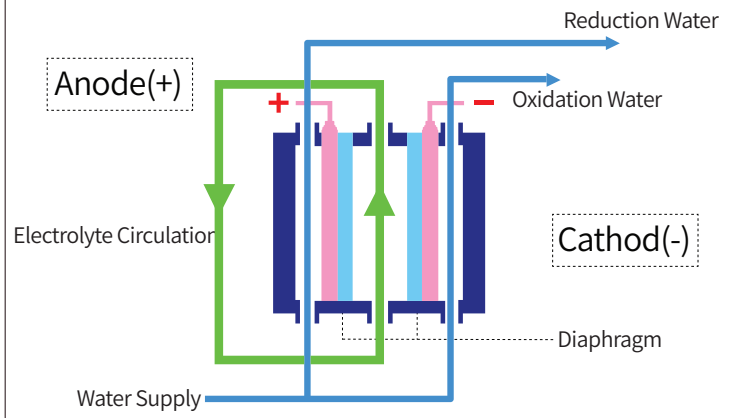

Accumulated Flow Fresh System

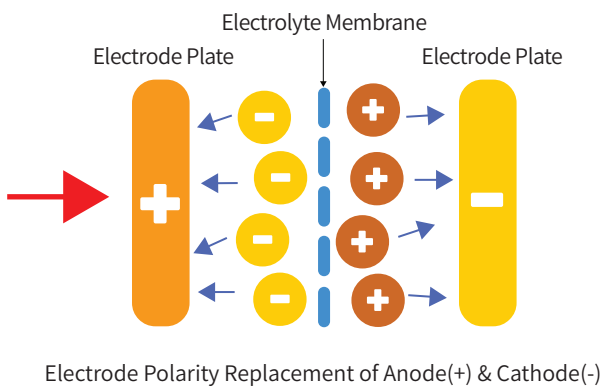

PRODUCT DESCRIPTION

TITLE		S7000P
Product Name	Water Ionizer	
Feature	3 Selection of Alkaline, Acidic and Purified with diatomic Hydrogen Ion (1500ppb)	
Operation Type	One touch with voice / LED display	
Voltage	AC 110-230V 60Hz / Free Voltage	
Power/Applicable water PSI	200VA Available at the water with hardness / 85.3 psi (0.7 ~ 6.0kgf.cm ²)	
Size / Weight	Net 4kg / 3ea a carton 18kg 40x70x47cm	
Water Supply	Direct connection to a source water	
Water temperature	5 ~ 30°C	
Power Supply	SMPS / Maximum Power Consumption 450W/A	
Electrolysis Device	Output Rate	3.0 ~ 4.0L/min
	Steps	Alkaline 5 level, Acidic 5 level, Purified 1 level
	Cleaning Device	Smart Automatic Cleaning on flow rate and time
Purified Device	Electrode Materials	Platinum and Titanium 7 Plate (Private Electrolysis Device-ownership of molding) Thickness: Max 0.3μm for Anti Scale and Endurance
	Filter Replacement	2Filter / Sliding at Front
	Filter Lifespan	No.1 : 0,2,400L (approx. 6M), No.2: 4,800L (approx. 12M) 2 carbon filter
Origin & Warranty	Made in Korea / 1 year	

